

Submersible drainage pumps for hot clear water and drainage water. Spherical clearance 10 – 28 mm.

H 307, H 313, H 328 V

Application

HOMA H 300 are submersible drainage pumps for pumping clear water or drainage water with high temperatures. With the advantage of thick wall casting for dissipation of heat and viton seals, they are the ideal solution to pump condensate, clear water or drainage water up to 90°C. The models H 307 and H 313 are used for pumping clear water or drainage water up to 10 mm spherical clearance, model H 328 V up to 28 mm spherical clearance. They are suitable for laundries, car washes, food industries and many other applications.

DIN EN 12050-2: Conformity and design approved and controlled by LGA, certificate No. 0220119.

Installation: Transportable or permanent. Models with float switch control for automatic pump operation, depending on liquid level in the sump.

Pumped liquid: Condensate, clear water or drainage water.

Max. liquid temperature: 90°C

Operation: Intermittent.

Design

Fully submersible, compact integrated motor-pump unit consisting of:

Pump: Single stage centrifugal pump with horizontal discharge BSP 1 1/2" F.

Impeller: H 307, H 313: open multi-channel impeller, spherical clearance 10 mm. H 328 V: Vortex impeller, spherical clearance 28 mm.

Motor: Fully submersible, pressure tight electric motor, oil filled. Insulation class F. Degree of protection IP 68.

Cable: BI HF-J 4 x 1,5

Model WA: BI HF-J 5 x 1,5

Shaft/Bearing: Large diameter stainless steel rotor shaft, pre-lubricated bearings.

Seals: Combination of mechanical seal (silicon-carbide) and lip-seal (viton).

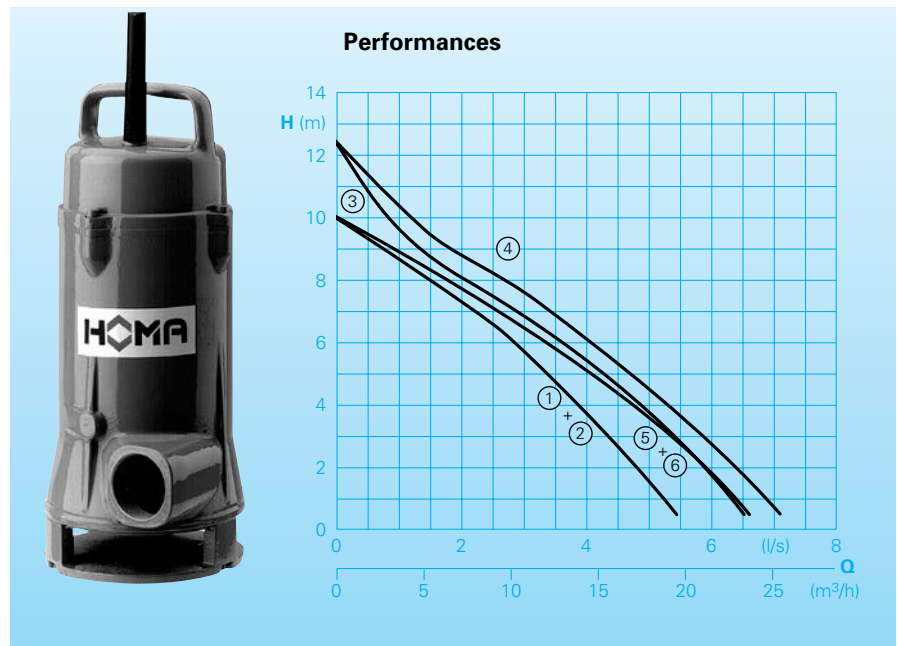

Technical Data

Curve No.	Pump type	Motor-input P ₁ (kW)	Motor-output P ₂ (kW)	Capacitor* (μF)	Speed (rpm)	Nominal current (A)	Weight (kg)
①	H 307 W(A)	0,8	0,5	20	2900	3,4	18
②	H 307 D(A)	0,7	0,5		2900	1,3	18
③	H 313 W(A)	1,0	0,7	25	2900	4,3	18
④	H 313 D(A)	1,2	0,9		2900	2,2	20
⑤	H 328V W(A)	1,2	0,9	25	2900	5,2	20
⑥	H 328V D(A)	1,2	0,9		2900	2,2	20

Model W: 230-240 V / 1 Ph

Model D: 400-415 V / 3 Ph

* Capacitor: For the operation it is necessary to install a capacitor in the control box.

Model A: With automatic level

control HOMA-Nivomatik

Materials:

Suction sieve, suction cover, motor bearing housing, motor housing, motor housing cover, impeller	Cast iron GG 25/EN-GJL-250
Rotor shaft, screws	Stainless steel
Seal kit	Viton
Cable	Silicon

Equipment supplied

Model W (230-240 V/1 Ph): Control box W19 fitted with overload protection, on-off switch and 10 m of cable, capacitor and plug.

Model D (400-415 V/3Ph): Control box D32 fitted with overload protection, on-off switch and 10 m of cable, phase inverter.

Model A: With additional automatic level control, control box WA05/19 or DA05/32 with manual-auto-switch and 5 m of cable.

Dimensions and Installations

**H 307,
H 313**

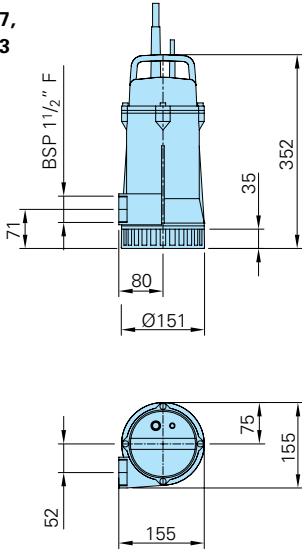

H 328 V

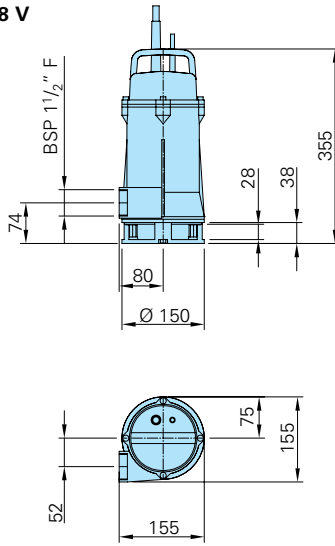

all dimensions in mm

Permanent sump installation with auto-coupling system.

Permanent installation utilising a submerged auto-coupling guide rail system for automatic connection and disconnection of the pump from the pipework from outside the sump. Applicable for single or multi pump stations.
Advantages: Little space requirement, easy pump service and maintenance.

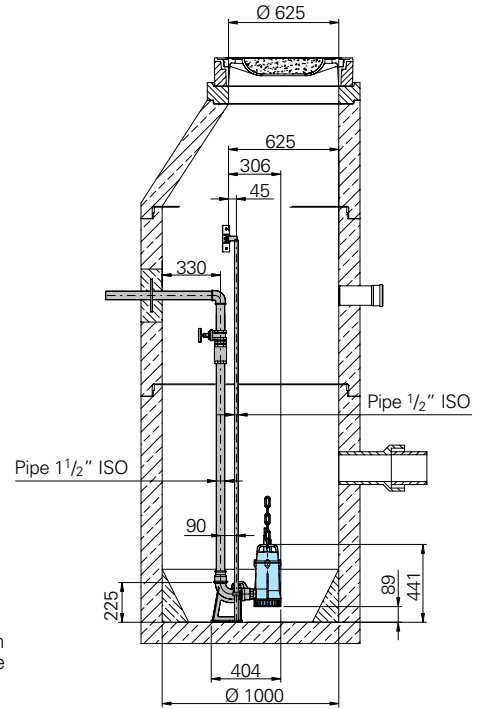

Accessories

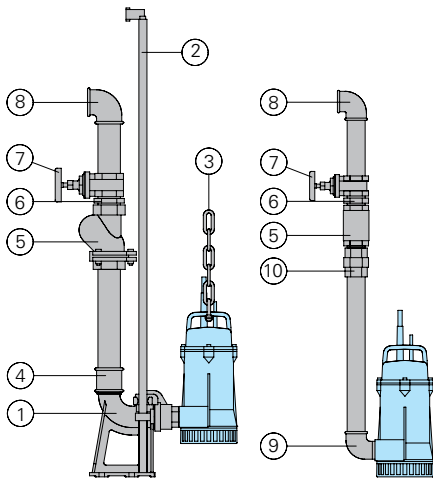

Part Description	Dimension	Part No.
① Auto-coupling system type KK 50/R 1 1/2" with: - Cast iron auto-coupling with flange - Cast iron flanged pump and double nipple - Cast iron upper slide rail bracket	BSP2" M BSP1 1/2" F BSP1 1/2" M 1 1/2"	8604000
○ Auto-coupling system complete or partial in stainless steel	all types	on request
○ Screw-kits for installation of coupling system		on request

Part Description	Dimension	Part No.
② Guide rails, pair, per m steel galvanized stainless steel	1/2" dia. 1/2" dia.	2190085 2190250
③ Lifting chain, per m steel galvanized stainless steel	5 mm dia. 5 mm dia.	2800350 2800353
Shackle steel galvanized stainless steel	for chain 5 mm dia. for chain 5 mm dia.	2801450 2801390
④ Galvanized double socket	BSP 2" F BSP 2" Fx BSP 1 1/2" F	2109102 2102210
⑤ Cast iron swing check valve	BSP 1 1/2" F BSP 2" F	2212902 2212903
⑥ Galvanized double nipple	BSP1 1/2" M BSP 2" M	2009020 2009018
⑦ Bronze gate valve	BSP 1 1/2" F BSP 2" F	2216015 2216020
⑧ 90° galvanized elbow	BSP 1 1/2" F BSP 2" F	2113605 2113606
T-piece for twin pump arrangement	BSP 1 1/2" F BSP 2" F	2114302 2114306
⑨ 90° galvanized elbow	BSP 1 1/2" F/M BSP 2" F/M	2111505 2111506
⑩ Galvanized pipe union	BSP 1 1/2" F/M	2114305
○ Brass STA hose coupling	BSP 1 1/2" M	2001513
STORZ-fixed coupling	C-BSP 1 1/2" M	2010003
○ PVC-hose, per m	1 1/2"	2621500
Reinforced hose, per m	50 mm dia.	2632050
STORZ-hose coupling with spigot	C-38 dia. C-52 dia.	2013002 2013003
Hose bands	1 1/2" 2"	2304854 2306009

Part Description	Dimension	Part No.
○ HOMA-Nivomatik floatswitch level control conversion kit - for 230-240V/1Ph AZW 10/10 - for 400-415 V/3Ph AZD 10/10	length 10 m length 10 m	1435105 1914452
○ Homa 2 poles earth circuit breaker Fi 16/0,03 A		1561160
○ Alarm device AL3 Mains-operated with connector for battery 9 V (see below) for mains-independent operation integrated buzzer. Mains connection 230-240 V/1Ph		1586140
Battery for mains-independent operation		1952215
Floatswitch AS-100, max. medium temperature 100°C Cable length	5 m	1465710
○ Control panel for single or twin pump station for automatic operation		On request



HOMA Pumpenfabrik GmbH
P.O. Box 22 63, D-53814 Neunk.-Seelscheid
Tel. +49 (0) 22 47/702-0, Fax +49 (0) 22 47/702-44
e-mail: info@homa-pumpen.de
www.www.homapumps.com